

FINAL REPORT

MODEL STUDY OF  
CIRCULATING WATER PUMP SUMP

PAWNEE S.E. GENERATING STATION  
UNIT NO. 1  
PUBLIC SERVICE COMPANY OF COLORADO



Prepared for

Stearns - Roger Incorporated  
Denver, Colorado

by

Steven R. Abt  
and  
Cesar Mendoza

Colorado State University  
Engineering Research Center  
Civil Engineering Department  
Fort Collins, Colorado

May 1981

Engineering

JUN 18 1981

Branch

CER80-81SRA-CM53



U18401 0075853

## TABLE OF CONTENTS

	<u>Page</u>
I. INTRODUCTION . . . . .	1
Scope of the Model Study . . . . .	1
Model Criteria . . . . .	2
II. THE MODEL . . . . .	4
Model Construction . . . . .	4
III. MODEL TEST RESULTS . . . . .	9
Model Test Procedures and Observations . . . . .	9
General Flow Conditions . . . . .	11
Approach Basin . . . . .	11
Sumps . . . . .	12
Operational Water Levels . . . . .	17
Witness Tests . . . . .	18
IV. CONCLUSIONS AND RECOMMENDATIONS . . . . .	19
Recommendations . . . . .	19
REFERENCES . . . . .	22
APPENDIX . . . . .	23

LIST OF FIGURES

<u>Figure</u>		<u>Page</u>
1	Schematic Drawing of Model . . . . .	5
2	PSCC Pawnee Circulating Water Pump Sump . . . . .	6
3	Pump Columns and Suction Bells . . . . .	7
4	Plan View of Approach Basin . . . . .	13
5	Standing Wave Entering Sump . . . . .	13
6	Radial Flow into Bell Mouth at Pumping Rate of 115,000 gpm . . . . .	15
7	Placement of Divider Wall in Sump . . . . .	15
8	Pump Operation in a Modified Sump with Baffle Plates, Curtain Walls and Divider Wall in Place . . . . .	16
9	Recommended Modified Sump with Baffle Plates, Curtain Walls and Divider Walls in Place . . . . .	20

LIST OF TABLES

<u>Table</u>		<u>Page</u>
1	Proposed Test Program . . . . .	3
2	Model-Prototype Scale Ratio . . . . .	3
3	Maximum Vortimeter Readings . . . . .	10
4	Vortex Classification . . . . .	11
5	Water Surface Elevations During Operation . . . . .	17

## Chapter I

### INTRODUCTION

#### Scope of the Model Study

A hydraulic model study was conducted to evaluate the flow characteristics of the circulating water pump sump of the Pawnee S.E. Generating Station near Brush, Colorado. Water depths, velocity profiles, pump operation, sump geometry and peripheral water flows influence the performance of the pumping system. In most cases, a theoretical analysis of the sump design and its effect on pump operation cannot be made because of the complexity of the boundaries and the inability to describe them mathematically. Therefore, a physical model test becomes necessary to evaluate the effectiveness of the sump design.

The scope of this study includes:

1. Construct a scaled model of the circulating water pump sump including a portion of the adjacent cooling tower basin upstream of the basin overflow weir structure.
2. Conduct thirteen (13) test runs in accordance with the operating conditions listed in Table 1. During each run, measurements of flow profiles, velocity distributions and intensity of vortices in the sump will be observed and recorded. In addition, general flow patterns as well as undesirable phenomenon such as flow separation, eddies, standing waves, etc., shall be observed, identified and recorded.
3. Based on the test results, sump modification will be recommended for satisfactory pump sump flow conditions.

### Model Criteria

The model study was used to simulate and predict prototype performance. The principles of similitude were applied in the model tests.

The formation and dissipation of eddies and vortices are affected by gravitational, inertial, viscous and surface tension forces. All of these forces follow different scaling laws. However, surface tension and viscous forces can be neglected if the model is constructed at a relatively large scale and if the model is tested at high enough Reynolds number. The flow in the pump sump is primarily free-surface open channel flow and can be modeled according to the Froude criterion. A geometric scale ratio of 1:10 (model to prototype) was selected for the model. The scale ratio was based upon the testing facilities available, ease of construction and testing, model Reynolds number, and allowable construction tolerances. Tables 2 lists the characteristic model-prototype ratios based upon the 1:10 scale ratio.

Table 1. Proposed Test Program

Test No.	Pump 1	Pump 2	Conditions
1	X		Screens placed at end of bay divides
2	X	X	Screens placed at end of bay divides
3	X		Perforated baffle placed at end of bay divides
4	X	X	Perforated baffle placed at end of bay divides
5	X		Perforated baffle placed at base of sump slope
6	X	X	Perforated baffle placed at base of sump slope
7	X		Curtain wall
8	X	X	Curtain wall
9	X		Modification of entrance conditions
10	X	X	Modification of entrance conditions
11	X	X	Perforated baffle, curtain wall & divider wall
12	X		Perforated baffle, curtain wall & divider wall
13		X	Perforated baffle, curtain wall & divider wall

\*One pump operates at 115,000 gpm.

\*\*Two pumps operate at 94,000 gpm each.

Table 2. Model-Prototype Scale Ratio

Parameter	Scale Ratio		Absolute Magnitude	
	Function of Length Ratio	Numerical Ratio	Prototype	Model
Length	$L_r$	1:10	10 ft	1 ft
Area	$L_r^2$	1:100	100 ft <sup>2</sup>	1 ft <sup>2</sup>
Velocity	$L_r^{1/2}$	1:3.16	3.16 fps	1 fps
Discharge	$L_r^{5/2}$	1:316	316 cfs	1 cfs
Time	$L_r^{1/2}$	1:3.16	3.16 min	1 min

## Chapter II

## THE MODEL

Model Construction

The model was designed and constructed to conform to the following Stearns-Roger Incorporated (SR) and Ingersoll-Rand Company (IR) reference drawings:

<u>Drawing No.</u>	<u>Title</u>	<u>Company</u>
L-22666, C9-3	Cooling Tower Basin	SR
L-22666, C9-5	Cooling Tower Basin	SR
L-22666, C9-6	Circulating Water Pump Well	SR
L-22666, C9-7	Circulating Water Pump Well	SR
L-22666, S4-9	Miscellaneous Steel Structures	SR
- - -	Screen Dimensions	SR
C-73APH 36X4B	Circulating Water Pump	IR
- - -	Baffle Dimensions	IR

Dimensions of the model facilities and the arrangement are presented in Figure 1. Photographs of the completed model is shown in Figure 2. The model was constructed of wood, plexiglass, PVC and metal. The sump was constructed from plexiglass to enable easy visualization of the flow patterns. The framed wooden box located upstream from the sump represented a portion of the approach channel or basin leading to the pump sump.

The pump columns and suction bells were fabricated from polyvinyl chloride and were machined conforming to the manufactures shape and dimensions as shown in Figure 3. Both pumps were instrumented with vortimeters to observe and record flow rotations occurring at the pump bells.

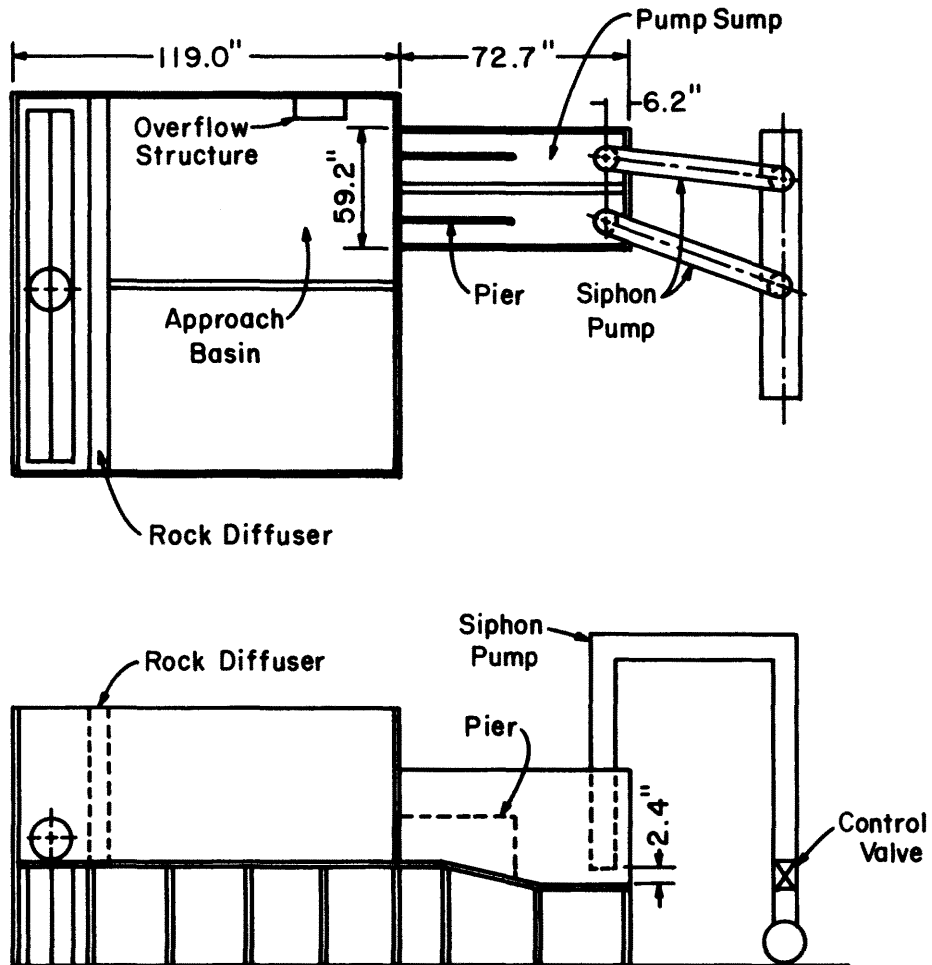

Figure 1. Schematic Drawing of Model

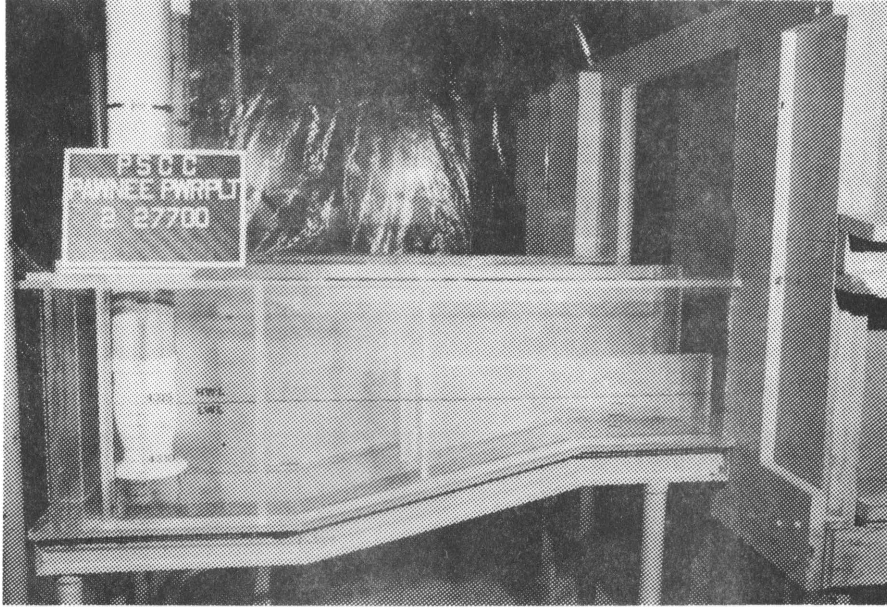

Figure 2a. Profiles of PSCC Pawnee C.W. Pump Sump

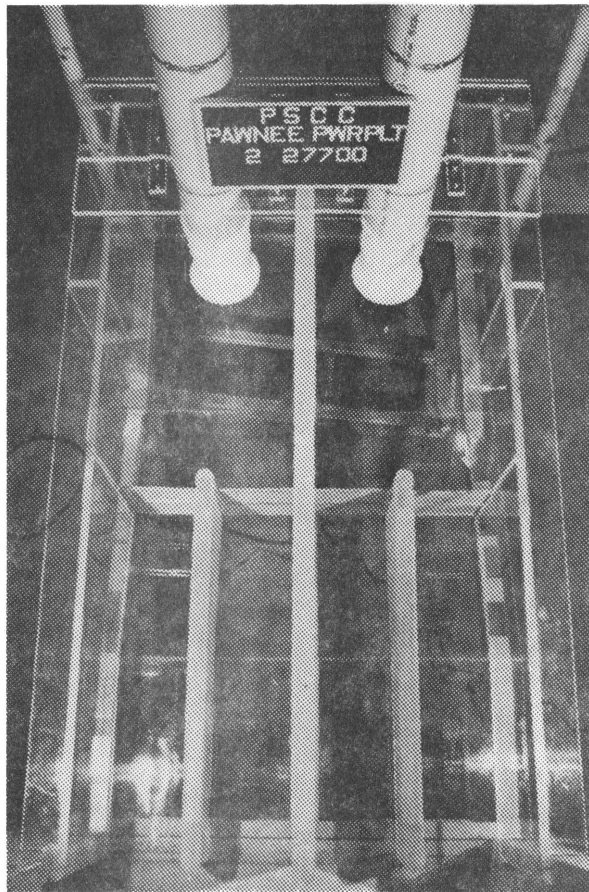

Figure 2b. Plan View of PSCC Pawnee C.W. Pump Sump

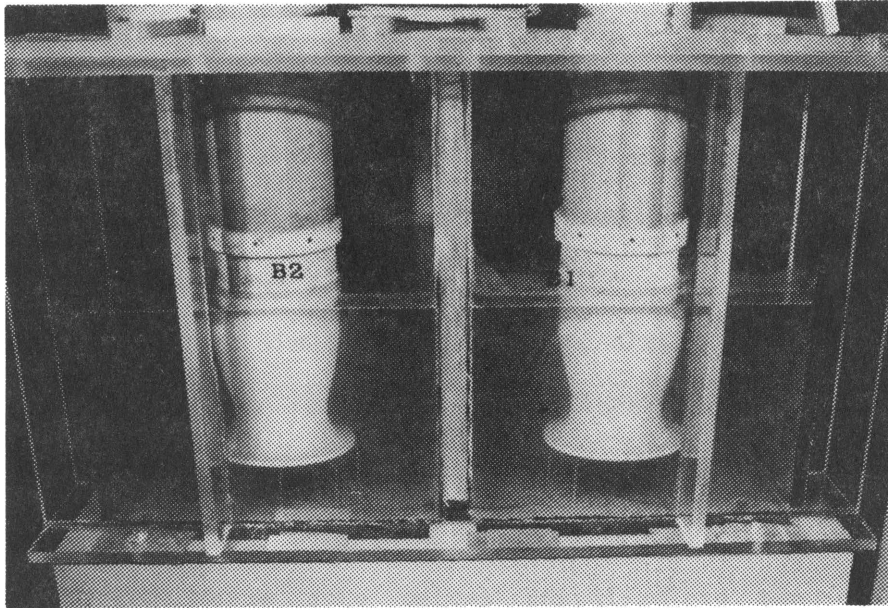

Figure 3. Pump Columns and Suction Bells

The vanes of the vortimeter were located in the throat of the pump suction bell corresponding to the approximate location of the prototype impellers. Eight woolen yarn strands attached to small brass pins were installed in the sump floor uniformly around each bell. The yarn strands were affixed to the tops of the pins which were installed above the sump floor. The length of each yarn strand was equal to the clearance between the pump suction bell and sump floor.

Water was supplied to the model by a 12-inch turbine pump. The flow entered the model through a diffuser that spread the flow over the width of the headbox. A rock baffle was used to distribute the flow uniformly into the approach basin.

The pump flows were simulated by siphonic action which withdrew the water from the sumps. The discharge through each siphon was measured by an elbow meter contained in each pump line. The meters were calibrated in the CSU calibration stand prior to installation in the model. The flow was adjusted using gate valves installed in the discharging siphons.

Perforated baffle plates, screens and curtain walls were fabricated for model testing. The perforated baffle plates were sized for an open area of 40% with circular 1/2 inch diameter holes. The screens were constructed with wire fabric and an approximate flow area of 77%. Adjustable curtain walls were fabricated for testing in the sump at various locations.

## Chapter III

## MODEL TEST RESULTS

Model Test Procedures and Observations

The model test program was designed to provide sufficient information to evaluate the prototype pump sump performance. Thirteen basic tests were performed using the general operating conditions presented in Table 1. In the first ten tests, the water surface elevation was maintained at approximately  $4316.0 \pm 0.1$  feet in the approach basin at a location 40 feet upstream of the sump entrance. The water surface was maintained at or below the 4316.0 feet elevation in the latter three tests (Test Nos. 11 through 13).

Steady state flow conditions were established at the beginning of each test. During each test, visual observations were made of: 1) the general flow patterns in the approach basin and sump; 2) the action of strands of yarn located on pins under and around the bell; and 3) the flow patterns in the vicinity of the bell enhanced by dye injections. Recorded data consisted of: 1) written comments relative to the visual observations; 2) the rotations of the vortimeters; 3) velocity traverses within the sumps; 4) photographs of the flow field exhibited by dye; and 5) photographs of the yarn strands placed on pins on the floor and around the bell.

The rotation of the vortimeters, the circulation around the pump column and the presence or absence of surface vortices were the principal criteria for defining satisfactory sump operation. Ideal sumps have zero rotation, however, an angular velocity of twenty (20) rpm is considered acceptable for satisfactory operation. The rotation of the vortimeter was not uniform and the angular velocity varied from

zero (0) to about fifty-six (56) rpm as presented in Table 3. The angular velocity reported herein was the maximum rotation obtained from at least four observations taken at random times during the run. The observer recorded the time required for the vortimeter to rotate 5 to 10 revolutions at a relatively uniform rate. The average rotation over a longer time period would be less than that recorded.

Table 3. Maximum Vortimeter Reading Observed in  
Revolutions per Minute

Tank No.	Pump #1	Pump #2
1	56	--
2	51	27
3	35	--
4	26	20
5	33	--
6	20	21
7	37	--
8	26	28
9	--	--
10	--	--
11	1	0
12	8	--
13	--	5

Velocity measurements in the sump were made in transverse vertical planes located 5 1/2 feet, 14 feet, 40 feet and 50 feet upstream from the centerline of the pump. Traverses using an OTT current meter were made at each of these vertical planes along horizontal lines at depths

of 0.3 times the flow depth and 0.7 times the flow depth measured from the water surface. Appendix 1 depicts the point velocity distributions at each cross section looking downstream. When a single pump operated at a discharge of 115,000 gpm, velocities near the sump entrance averaged approximately 5.5 fps. Operation of both pumps at a rate of 94,000 gpm each results in average entrance velocities of approximately 4.0 fps.

When vortices were observed in the model, they were classified by vortex type according to a scheme presented by Durgin and Hecker (1). The description of vortex type is presented in Table 4.

Table 4. Vortex Classification

Vortex Type	Description
1	Coherent surface swirls
2	Surface depression
3	Coherent dye core
4	Suction of slightly buoyant particles
5	Air bubbles pulled into intake
6	Full air core to intake

### General Flow Conditions

#### Approach Basin

The flow conditions entering the individual sumps were found to be nonuniform. Located upstream of the left sump, looking downstream, is an emergency overflow structure as shown in Figure 4. The presence of the overflow structure yields nonsymmetrical entrance conditions resulting in flow separation, shedding of eddies, and a redirection of streamlines. The overflow structure redirects the flow away

from the adjacent sump as illustrated in Figure 4. Flow must then accelerate when drawn into the adjacent sump, resulting in high velocities and a standing wave at the sump entrance as shown in Figure 5. Flows entering the sumps were found to have nonuniform velocity distributions between the sump piers resulting in a velocity differential and subsequent circulation around the pump column.

### Sumps

Flow patterns in the sump varied depending upon the tested modification (i.e., the screens, the perforated baffle plates or the curtain walls). In each of the first eight tests, screens, perforated baffle plates and curtain walls were individually verified in both single pump and dual pump tests. In each of these tests, poor flow conditions existed in which high vortimeter rotations, high entrance velocities, severe circulation around the pump column, and the presence of Type 1, 2, or 3 vortices were observed. Also, observation of the yarns at the floor indicated unstable, high rotational flows entering the pump bell near the rear sump wall. Flow separation at the lip of the bell mouth was observed with dye. The results of the first eight tests indicated that no single corrective measure tested would produce acceptable flow conditions in the sump for satisfactory pump operation.

Tests nine and ten investigated the effects of altering the entrance conditions while operating one and two pumps respectively. A variety of entrance modifications were observed to include; extending the divider piers upstream; extending the divider wall upstream; filleting the corners at the sump entrance; and filleting upstream and downstream of the emergency overflow structure. In each case, circulation around the pump column and surface vortices were not decreased or

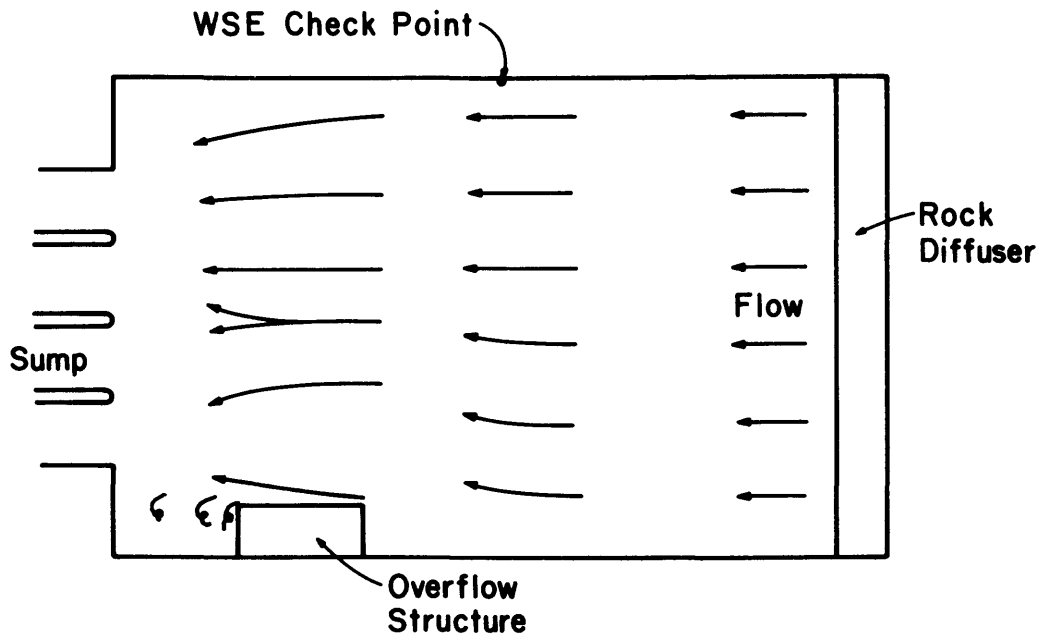

Figure 4. Plan View of Approach Basin

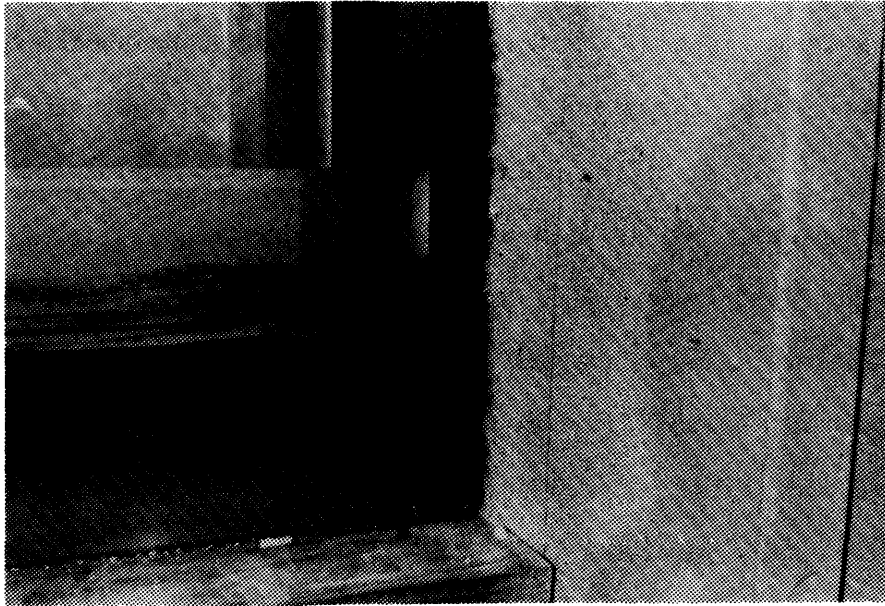

Figure 5. Standing Wave Entering Sump

dissipated in the model. It was therefore determined that modification of entrance conditions would not alleviate nor significantly improve the poor flow conditions in the sump.

Flow conditions were significantly improved by installing the perforated baffle plates in series with the curtain wall in each sump. The curtain wall was located approximately 11.0 feet upstream of the pump center line extending downward into the sump to an elevation of approximately 4313 feet. The perforated baffle plate was placed 14.7 feet upstream of the pump centerline which is one foot upstream of the manhole located over the bottom of the slope. The highest elevation of the baffle opening is 4314.0 feet. There were no perforations above elevation 4314.0 feet.

After installing the baffle plate and curtain wall, flow conditions were significantly improved by reducing circulation around the pump column and eliminating surface vortices and eddies. Vortimeter rotations were reduced although not eliminated. Flows entering the pump bell were radial as seen in Figure 6. Rotational flow was observed entering the bell near the rear sump wall.

A divider was placed along the back wall of the sump extending from the sump floor to approximate elevation 4310.6 feet centered along the pump vertical axis as illustrated in Figure 7. The divider extended approximately 1.6 feet from the rear sump wall toward the pump. Tests 11-13 verified pump operation with the perforated baffle plates, curtain walls and divider walls installed in the model as shown in Figure 8. Flow conditions and patterns in the sump were observed to be satisfactory for the operation of each pump separately at a discharge of 115,000 gpm and both pumps together at discharges of 94,000 gpm each. Rotations

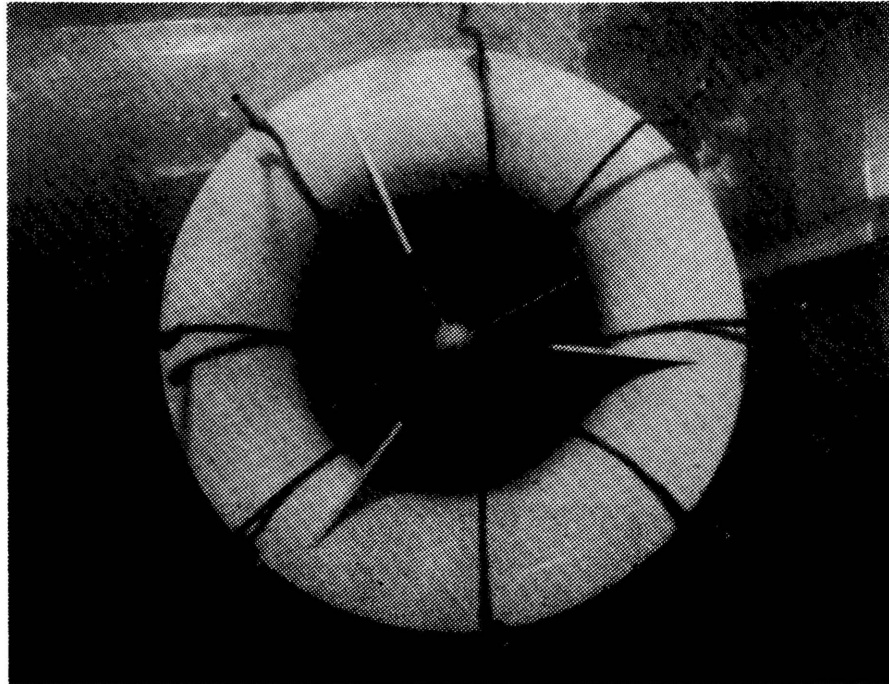

Figure 6. Radial Flow into Bell Mouth at a Discharge of 115,000 gpm.

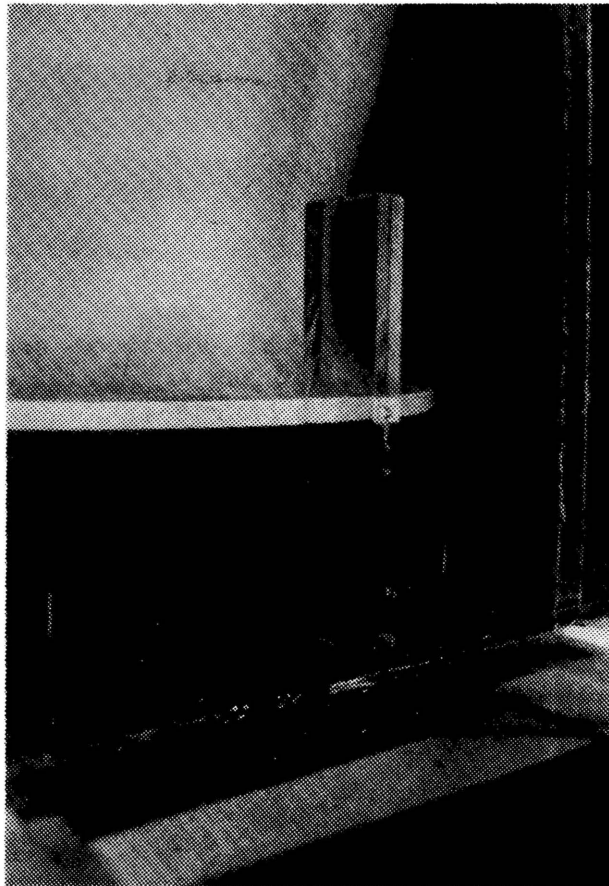

Figure 7. Placement of Divider Wall in Sump

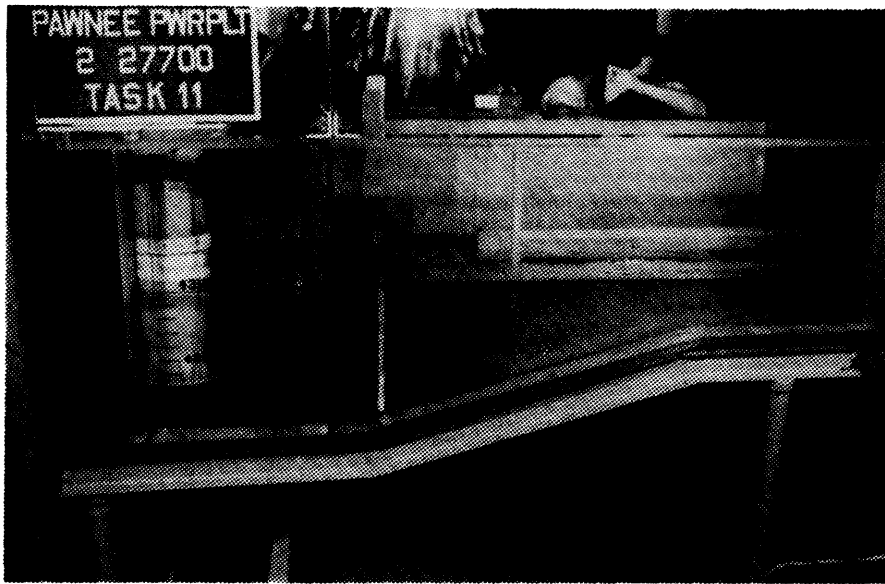

Figure 8. Pump Operation in a Modified Sump with Baffle Plates, Curtain Walls and Divider Wall in Place

of the flow entering the pump were less than 10 rotations per minute and free of vortices. Circulation was not observed around the pump column.

During each verification test, the screens were placed in the model. The screens were observed to have little or no effect on the prevailing flow conditions in the sump. Therefore, properly cleaned and maintained screens will not disrupt normal operation of the sump.

#### Operational Water Levels

Water surface elevations were observed and recorded during pump operation for tests 11-13. Water surface elevations are presented in Table 5.

Table 5. Water Surface Elevations During Operation

Operation		WSE in Basin (1)	WSE Near Entrance (ft.) (2)	WSE U/S of Baffle (ft.) (3)	WSE at Pump (ft.) (4)
Pump 1	Pump 2				
X		4315.5	4314.6	4314.8	4314.5
X		4316.0	4314.8	4315.4	4315.1
	X	4315.6	4314.6	4315.0	4314.5
	X	4316.0	4315.1	4315.5	4315.1
X	X	4315.1	4314.7	4314.4	4314.5
X	X	4316.0	4315.6	4315.5	4315.6

Water surface elevations (WSE) were recorded: (1) at a point 40 feet upstream of the sump entrance in the approach basin; (2) at a point approximately 2.5 feet downstream of the leading edge of the divider pier in the sump; (3) at a point on the upstream face of the perforated baffle plate; and (4) at the upstream edge of the pump column. A maximum operational water surface elevation of 4316.0 feet was maintained in the approach basin while a minimum operational water surface elevation of 4314.5 was maintained in the pump sump.

Witness Tests

Witness tests were performed on April 16, 1981. Mr. Fred F. Antunes and Mr. Richard MacDuff from Ingersoll-Rand Company, Mr. O. C. Wu, Mr. H. S. Miller, Mr. F. D. Schmit, and Mr. E. F. Miller of Stearns-Roger Incorporated, Mr. G. R. Miller, Mr. R. J. Blatnik, Mr. W. E. Wostenberg, and Mr. R. D. Gates of Public Service Company of Colorado observed the model performance. Conditions observed during the tests included discharges of 115,000 gpm for a single pump and 94,000 gpm each with both pumps operating. A variety of water surface elevations were observed.

## Chapter IV

## CONCLUSIONS AND RECOMMENDATIONS

Flow conditions were not satisfactory for prescribed discharges or pump operations when screens, perforated baffle plates, curtain walls or modified entrance conditions were separately tested in tests 1-10. Circulation around the pump columns, vortices, and high rotations at the pump intake were observed in each test. Flow separation under the outer edge of the bell was observed when dye was injected near the bell.

Flow conditions in the sumps were satisfactory when the perforated baffle plates, curtain walls and divider walls were installed together in the model as described in Chapter 3. Rotation of flow at the pump intake was reduced to 8 rpm or less as indicated by the vortimeter. The yarn strands indicated relatively good radial flow. Separation of flow under the outer edge of the bell was reduced and not considered detrimental to the performance of the pump. Vortices and eddies were eliminated in the sump downstream of the curtain wall. Circulation around the pump column was significantly reduced or eliminated. Installation of screens had little effect on the sump operation when screens were cleaned and maintained.

Recommendations

It is recommended that the present pump sump design be modified to incorporate baffle plates, curtain walls and divider walls into the prototype to improve the pump sump flow conditions. Perforated baffle plates should be installed in each sump as illustrated in Figure 9. The baffle plates should be placed approximately 14.7 feet upstream of the pump centerline which is one (1) foot upstream of the manhole located over the bottom of the slope. The elevation of the highest baffle

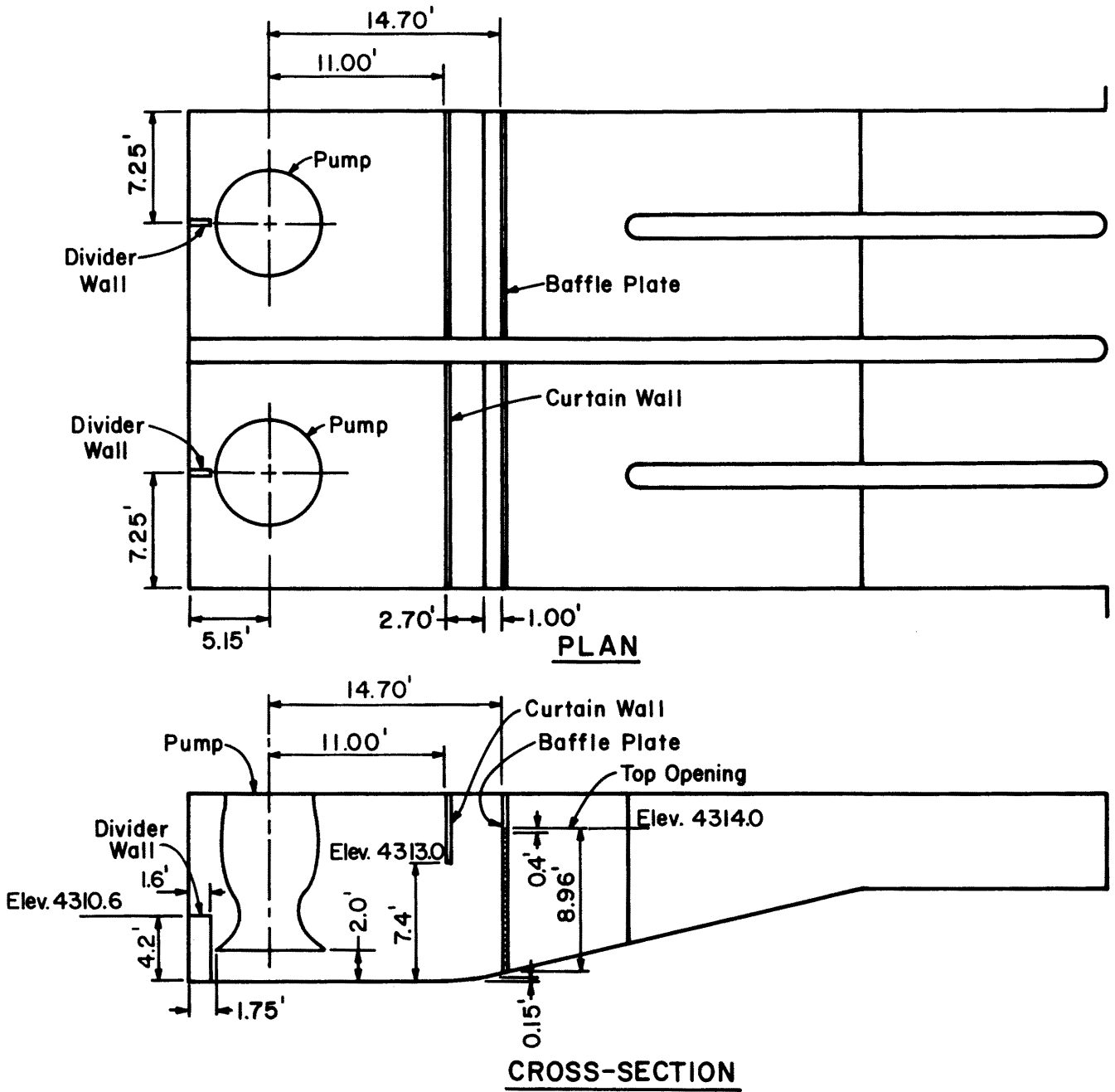

Figure 9. Recommended Modified Sump with Baffle Plates, Curtain Walls and Divider Walls in Place

opening is 4314.0 feet. There should not be any perforations located above elevation 4314.0.

It is recommended that a curtain wall be installed in each sump. The curtain wall should be placed approximately eleven (11) feet upstream of the pump centerline and extend downward into the sump to where the bottom of the curtain wall is elevation 4313.0 feet. The curtain wall should have no perforations and be adjacent to the sump side walls.

It is recommended that a divider wall be placed along the back wall of each sump extending from the sump floor to approximate elevation 4310.6 feet centered along the pump vertical axis. The divider should extend approximately 1.6 feet from the rear sump wall toward the pump.

Screens can be utilized during sump operation. However, screens should be kept clean and be well maintained.

## REFERENCE

- Durgin, W. W. and Hcker, G. E., 1978. The Modeling of Vortices at Intake Structures. Joint Symposium on Design and Operation of Fluid Machinery, Proceedings, Vol. I, pp. 381-391. Colorado State University, Fort Collins, Colorado.

**APPENDIX**

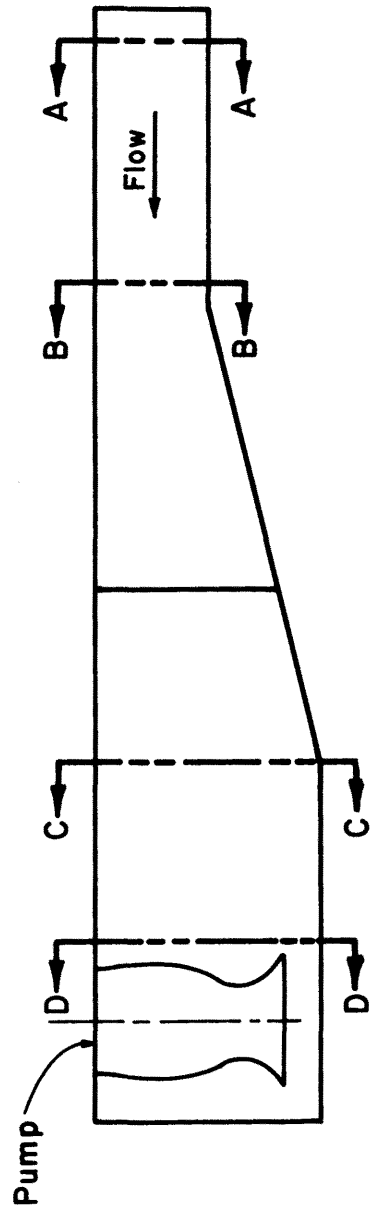

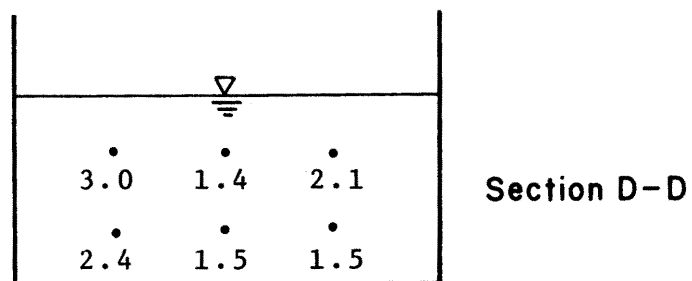
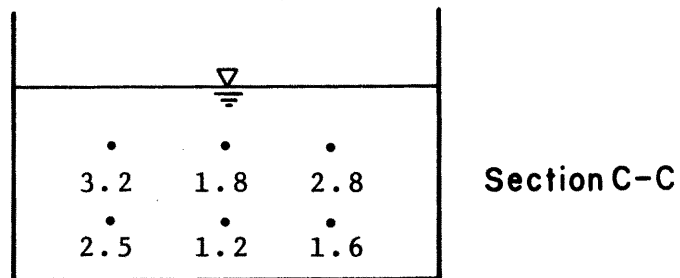
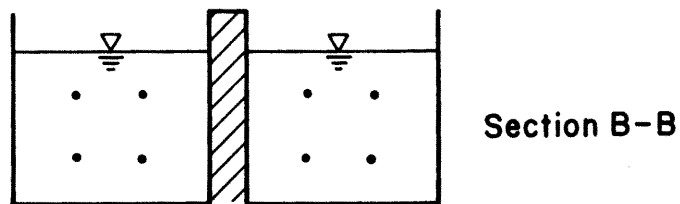
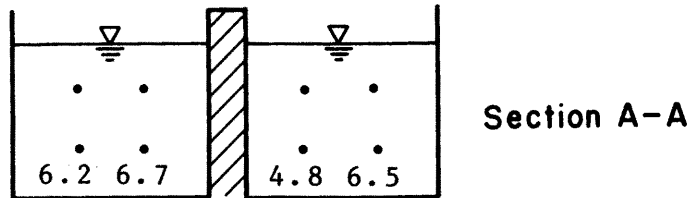
Task 1Bay 1NOTES

- 1) Velocity in ft per sec.
- 2) All cross sections looking downstream.
- 3) The velocity profiles were taken at 0.3 D and 0.7 D where D is the depth of flow.

Task 2

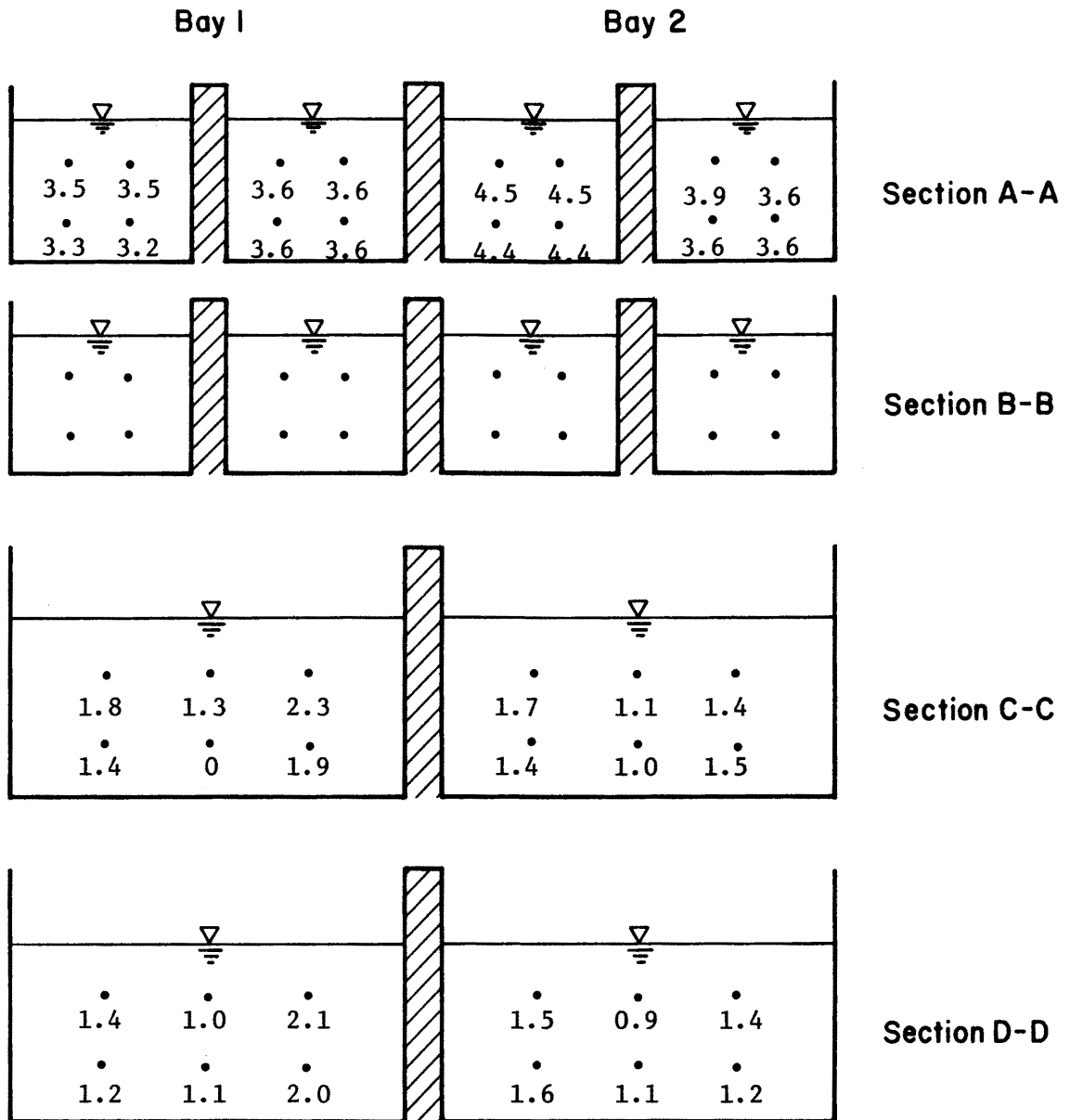

NOTES

- 1) Velocity in ft per sec.
- 2) All cross sections looking downstream.
- 3) The velocity profiles were taken at 0.3 D and 0.7 D where D is the depth of flow.

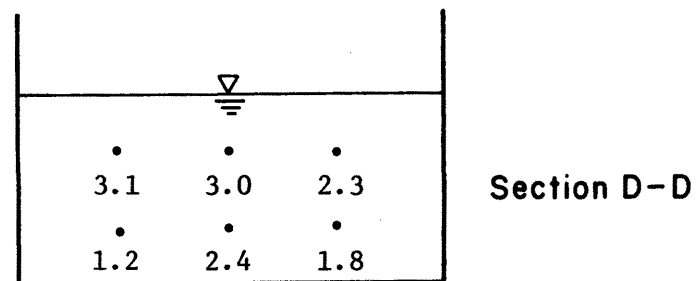
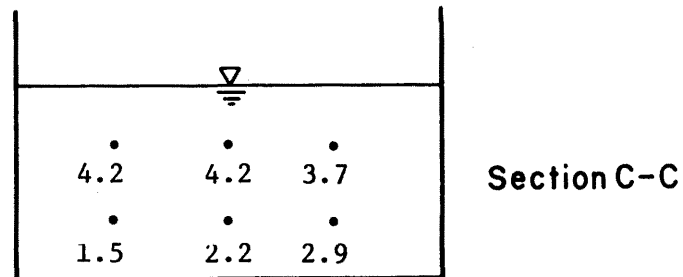
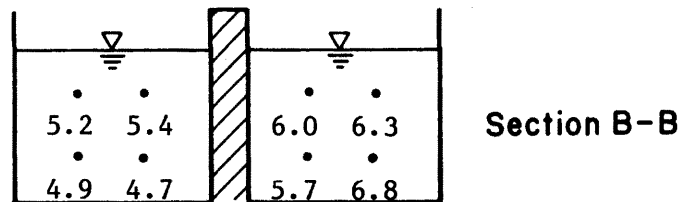
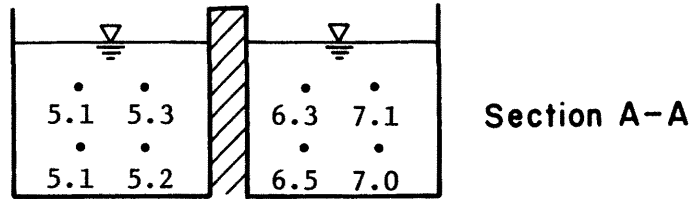
Task 3Bay 1NOTES

- 1) Velocity in ft per sec.
- 2) All cross sections looking downstream.
- 3) The velocity profiles were taken at 0.3 D and 0.7 D where D is the depth of flow.

Task 4

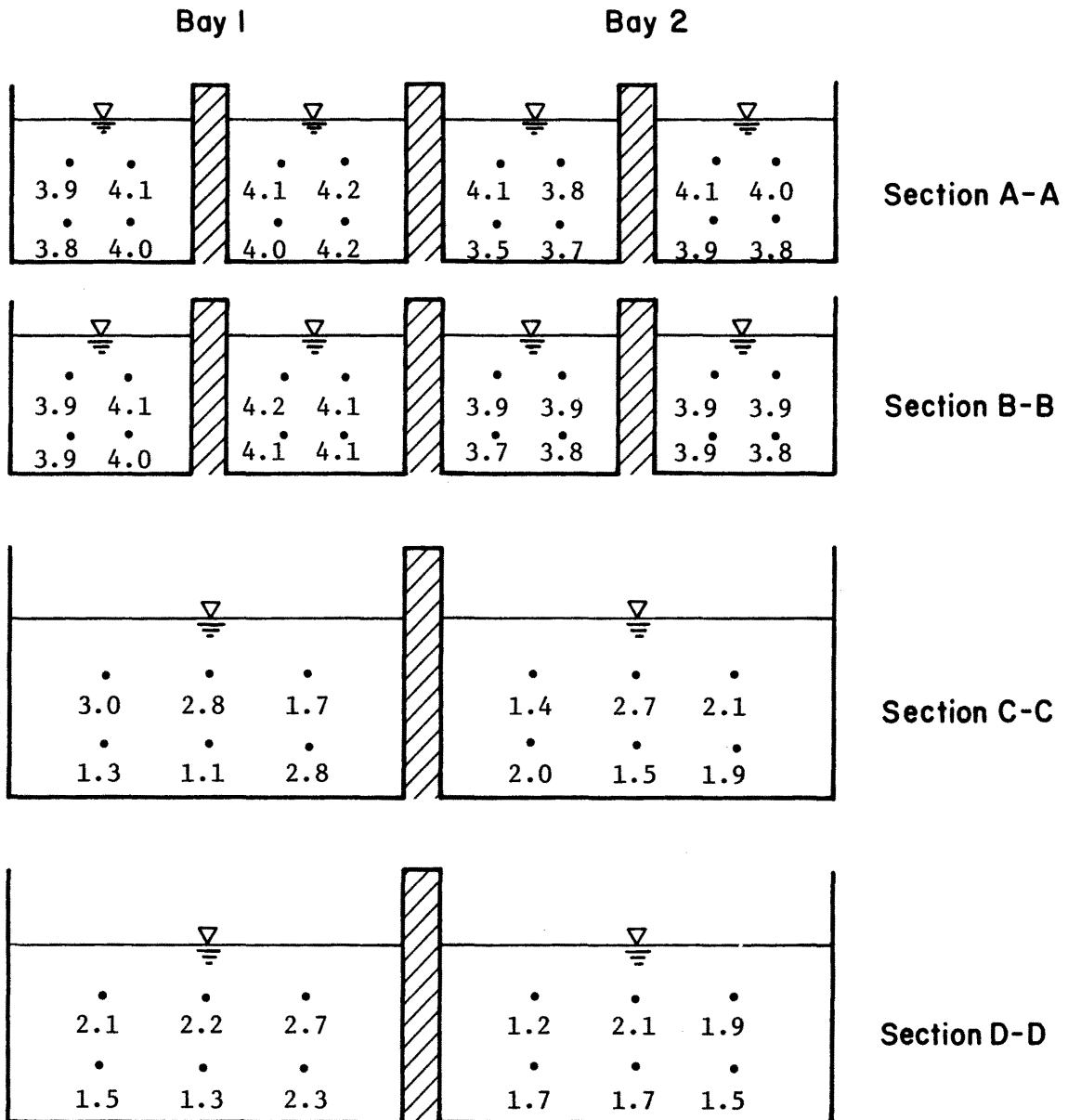

NOTES

- 1) Velocity in ft per sec.
- 2) All cross sections looking downstream.
- 3) The velocity profiles were taken at 0.3 D and 0.7 D where D is the depth of flow.

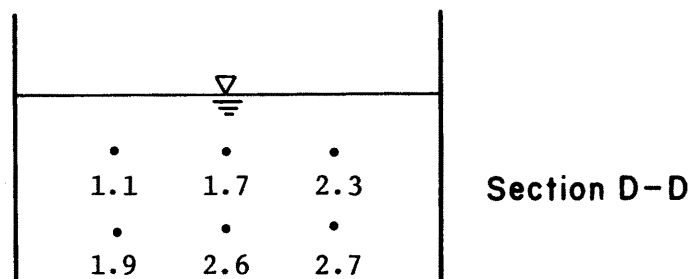
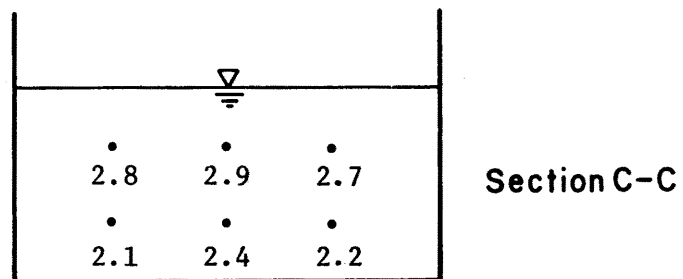
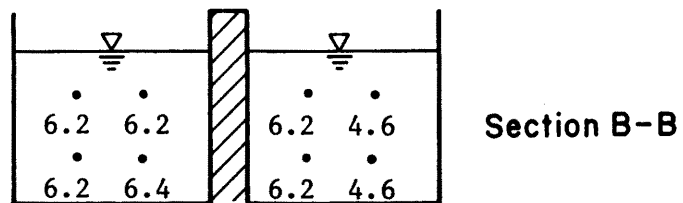
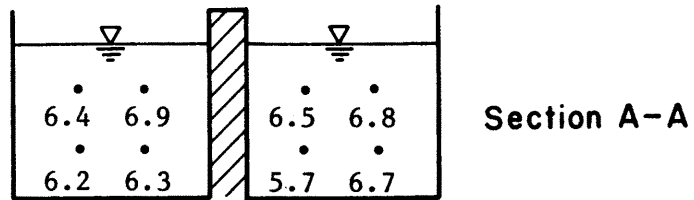
Task 5Bay 1NOTES

- 1) Velocity in ft per sec.
- 2) All cross sections looking downstream.
- 3) The velocity profiles were taken at 0.3 D and 0.7 D where D is the depth of flow.

Task 6

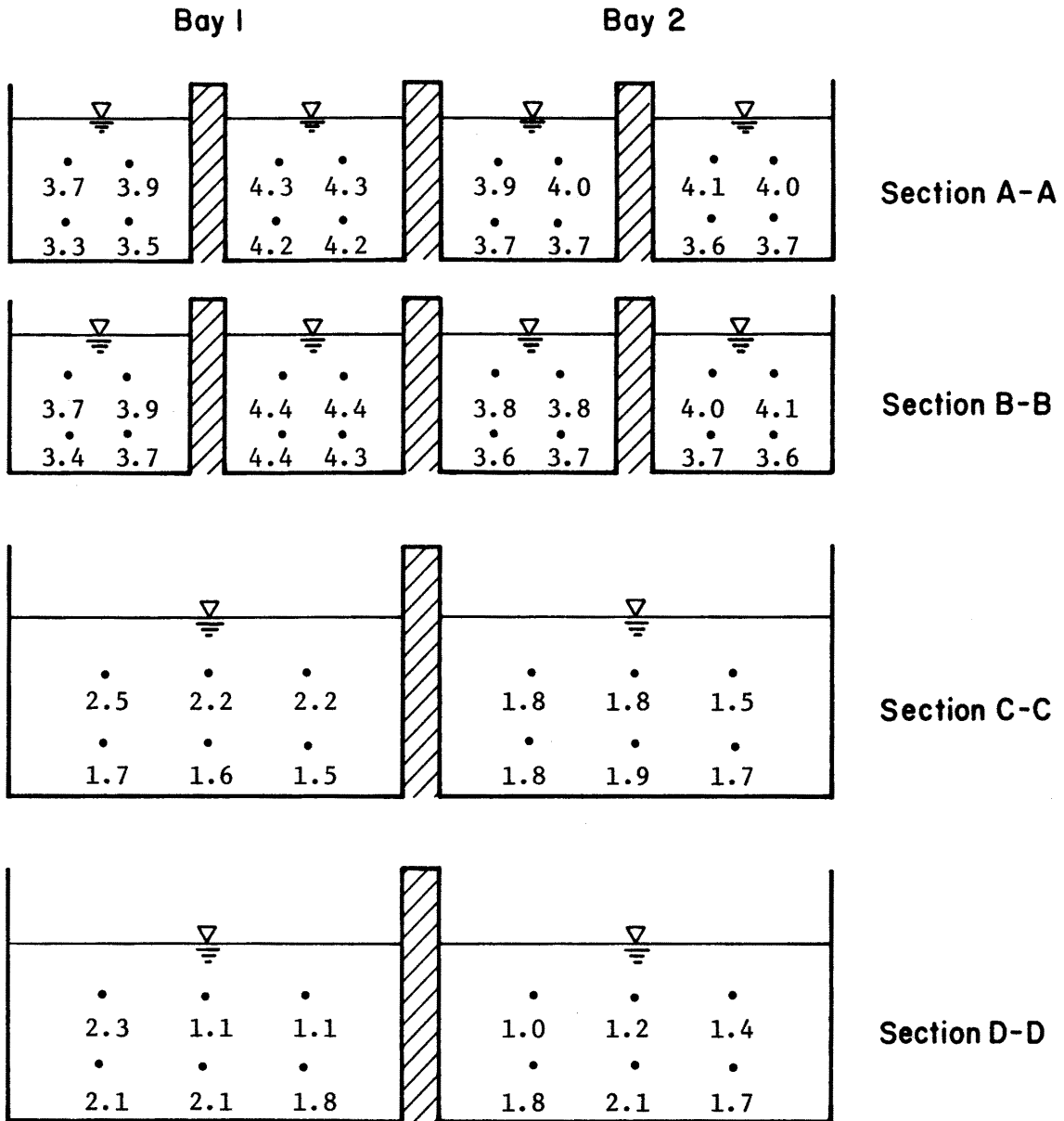

NOTES

- 1) Velocity in ft per sec.
- 2) All cross sections looking downstream
- 3) The velocity profiles were taken at 0.3 D and 0.7 D where D is the depth of flow.

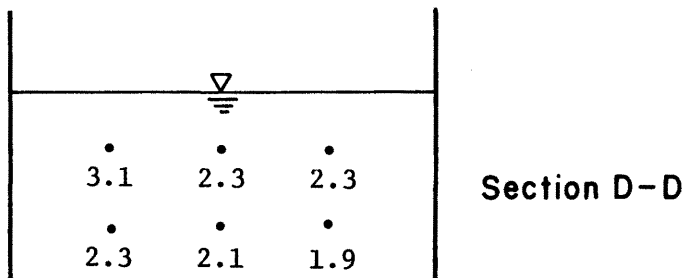
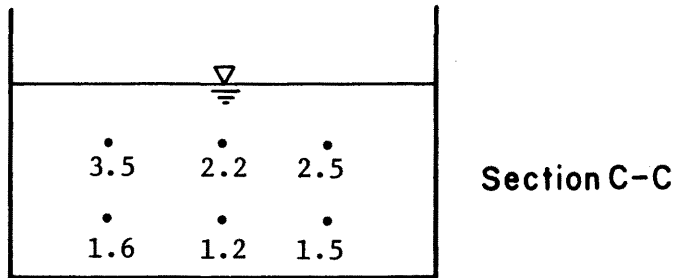
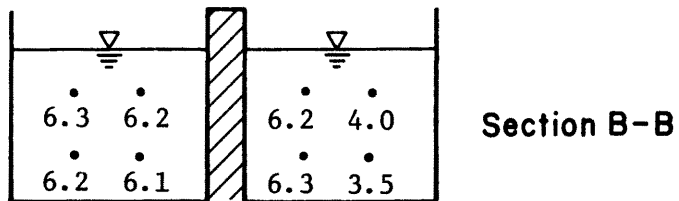
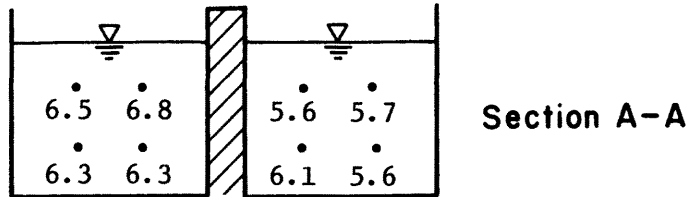
Task 7Bay 1NOTES

- 1) Velocity in ft per sec.
- 2) All cross sections looking downstream.
- 3) The velocity profiles were taken at 0.3 D and 0.7 D where D is the depth of flow.

Task 8

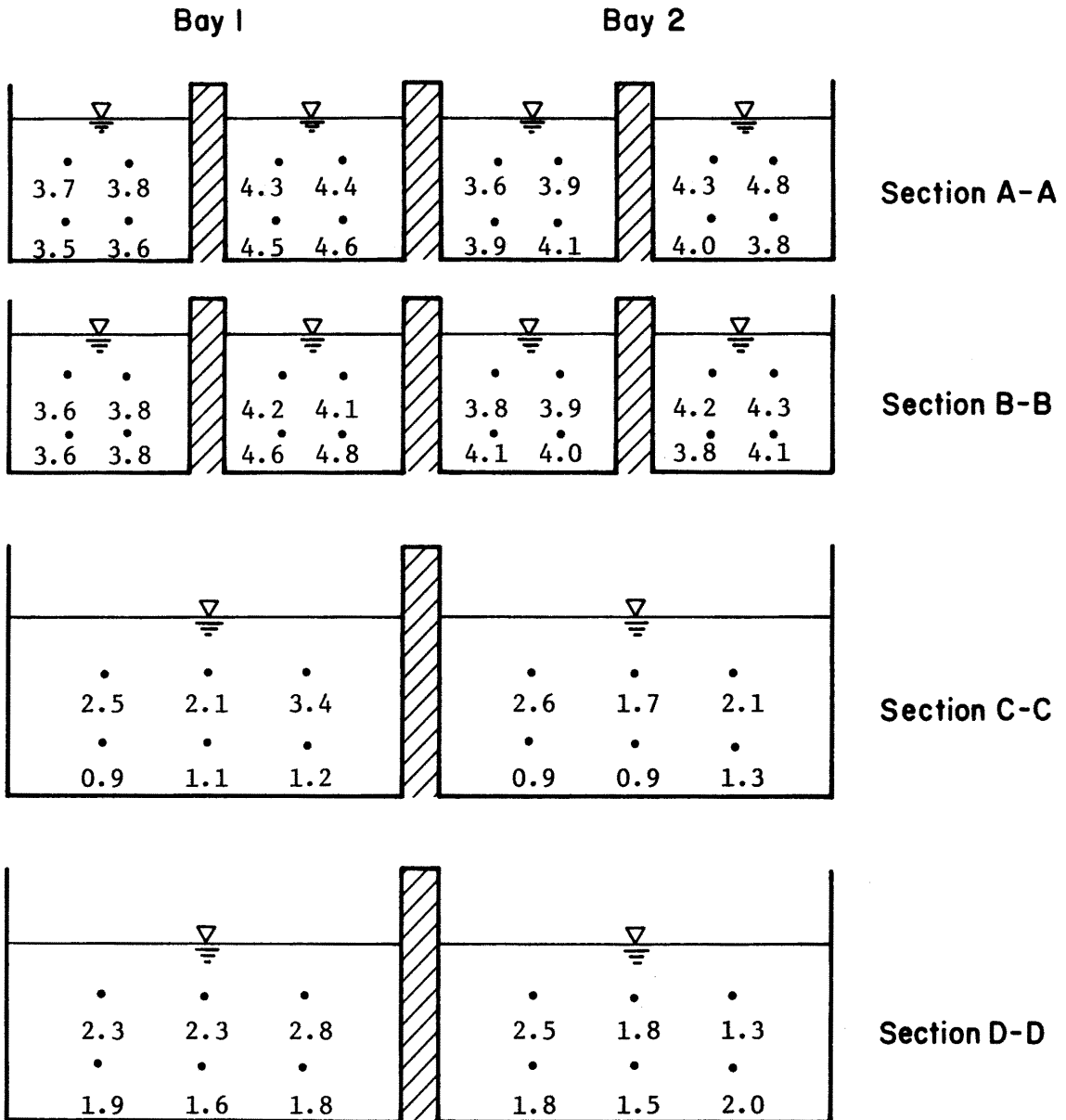

NOTES

- 1) Velocity in ft per sec.
- 2) All cross sections looking downstream.
- 3) The velocity profiles were taken at 0.3 D and 0.7 D where D is the depth of flow.

Task 11

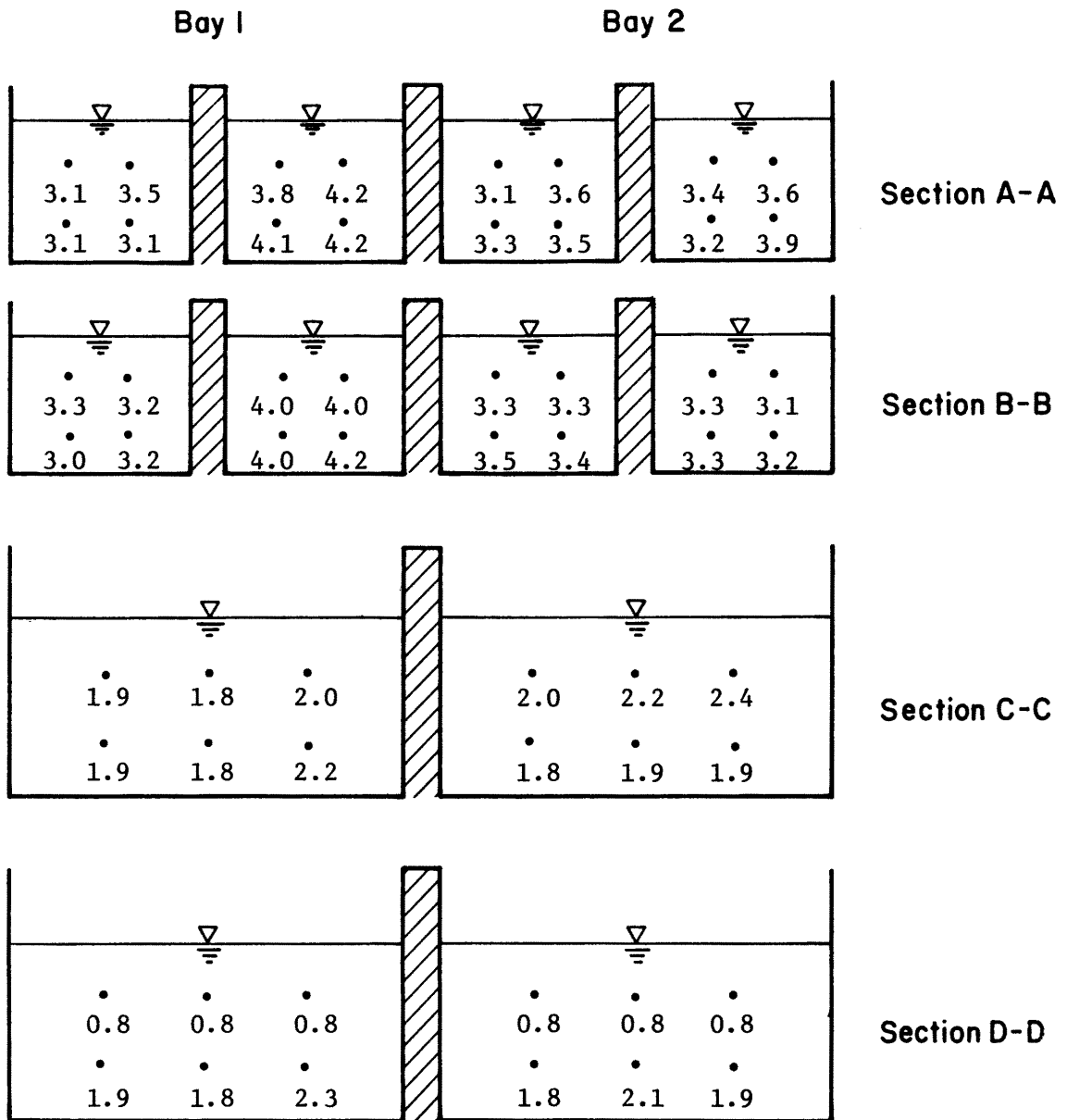

NOTES

- 1) Velocity in ft per sec.
- 2) All cross sections looking downstream.
- 3) The velocity profiles were taken at 0.3 D and 0.7 D where D is the depth of flow.

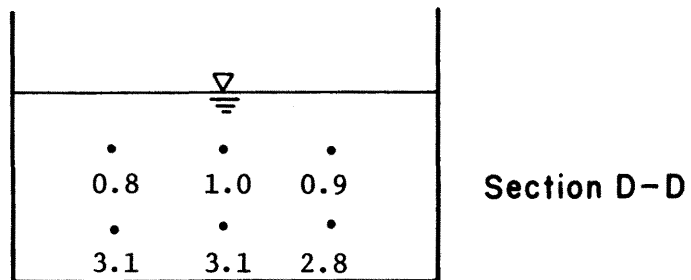
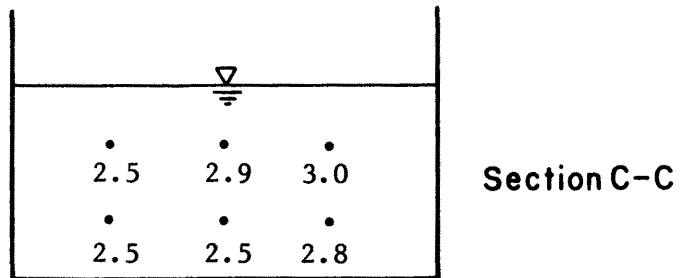
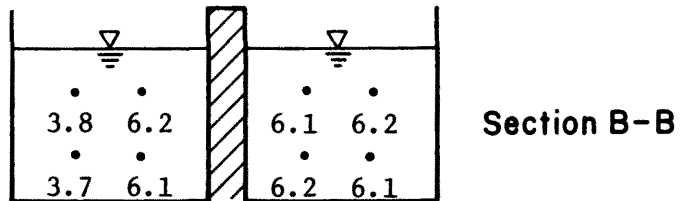
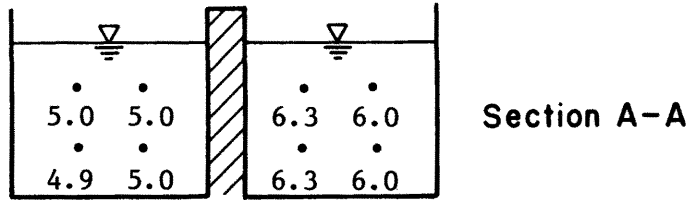
Task 12Bay 1NOTES

- 1) Velocity in ft per sec.
- 2) All cross sections looking downstream.
- 3) The velocity profiles were taken at 0.3 D and 0.7 D where D is the depth of flow.

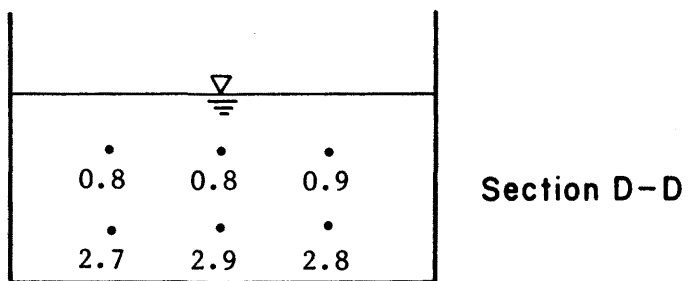
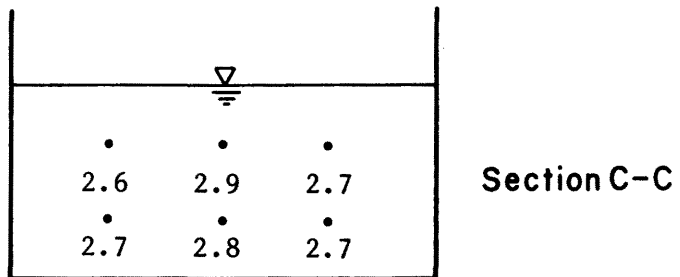
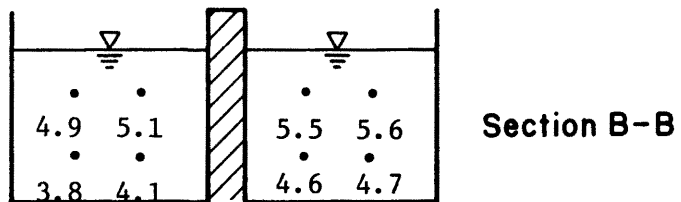
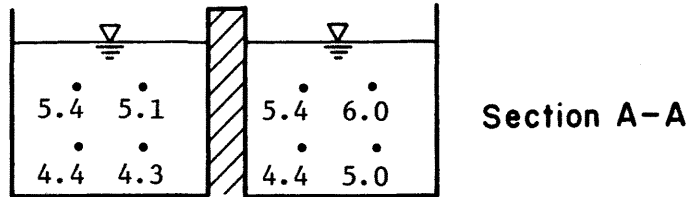
Task 13Bay 2NOTES

- 1) Velocity in ft per sec.
- 2) All cross sections looking downstream.
- 3) The velocity profiles were taken at 0.3 D and 0.7 D where D is the depth of flow.